

## Machine Parameters

Drive			Electric
Operation			Pedestrian
Nominal load capacity	Q	kg	1500
Load center distance	C	mm	600
Load distance	X	mm	895
Wheel base	Y	mm	1195
Empty weight (incl. Battery)		kg	230
Axle loading, laden (front/rear)		kg	841/889
Axle loading, unladen (front/rear)		kg	36/194
Tyres			PU
Tyres size (front)	front		Ø190x60
Tyres size (rear)	rear		Ø80x70
Additional wheels(option)			Ø60x35
Wheels, number (x = driven)			1x /4
Tread (rear)	b11	mm	390/525
Lift	h3	mm	115
Drawbar height in driving position (min/max)	h14	mm	650/1187
Forks height, lowered	h13	mm	80
Overall length	l1	mm	1660
Length to face of forks	l2	mm	510
Overall width	b1	mm	550
Fork dimensions ISO 2331	s/e/l	mm	55/160/1150 (1220)
Distance between forks arms	b5	mm	550/685
Ground clearance wheel base center	m2	mm	30
Aisle width for pallets 1000x1200 crossways	Ast	mm	1860
Aisle width for pallets 800x1200 lengthways	Ast	mm	1910
Turning radius	Wa	mm	1405
Travel speed (laden/unladen)		km/h	3.5/4
Lifting speed (laden/unladen)		m/s	0.17/0.20
Lowering speed (laden/unladen)		m/s	0.48/0.3
Max. gradeability (laden/unladen)		%	6/16
Service brake			Electromagnetic
Drive motor,S2 60min		kW	0.55
Lifting motor,S3 10%		kW	0.5
Battery Voltage	U	V	24
Battery capacity K5		Ah	30 ( LI-ION )
Battery weight		kg	50
Energy consumption according to VDI cycle		kW/h	0.18
Type of drive unit			DC
Sound pressure Level LpAZ		dB(A)	75

## Machine 2D Graph

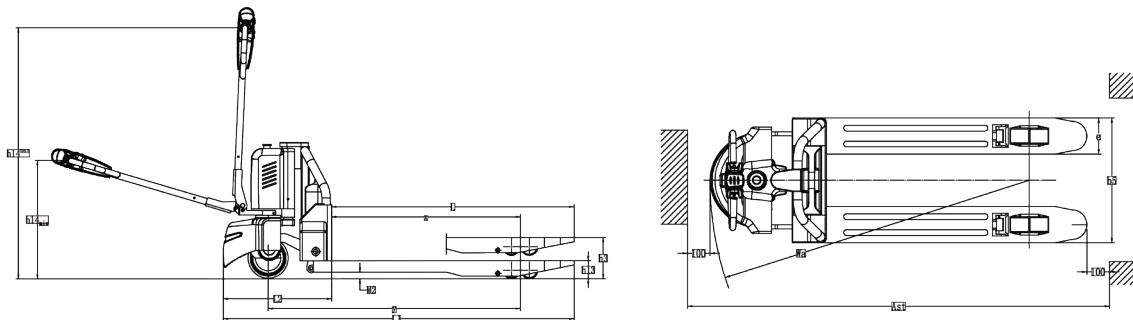

# ZOOMLION

WOW, It's **LI-ION**



## ⚡ Top Reliability

- 1 Hydraulic, electrical and driving systems are Independently located within the chassis. Main cables do not rotate while steering, reducing wear while increasing reliability.
- 2 All connectors are IP65 waterproof. This allows for outdoor Applications even when raining.
- 3 Column and floor structure made of 8 mm thick steel. This allows for strong torsional stability and increases lifespan of unit.





## ⚡ Serviceability

- 1 3 years maintenance free Lithium-ion battery warranty.
- 2 Low maintenance and easy access CAN-BUS system.



## ⚡ High Efficiency

- 1 30Ah 2hrs fast charging 
- 2 10s Replacing battery 
- 3 4hrs working time 
- 4 6% full load gradeability due to powerful gearbox and drive wheel.

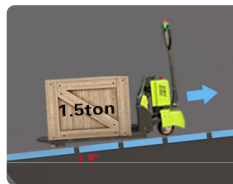

- 5 Ergonomic tiller arm with LED Password access, eliminates the risk of key loss. Turtle speed mode allows for exact and secure manoeuvrability when working in narrow aisles.



- 3 Optimized drivetrain guarantees easy access and replacement of PU wheel. (No disassemble of drivetrain required.)

