



MOVING YOU FURTHER

80D-9



Some of the photos may include optional equipment.

Your satisfaction is our priority!

Proven performance! The best design! Hyundai 9 Series Diesel Mid-size Forklift

Hyundai introduces a new line of 9 series diesel forklift.

The newly designed models provide every operator comfortable driving, increased productivity and easy maintenance.



- Powerful performance
- Spacious operating space
- Grammer seat (hot wire) as a standard
- Switch-type parking brake
: Parking brake operates automatically when the operator leaves the forklift.
- 4.3 inch LCD color monitor
- Machine inclination warning system
- Speed limit setting
- Operator presence sensing system (OPSS)
- Full Automatic Temperature Control (FATC) air-Conditioner



Power & Performance

High Efficiency, Optimal Performance

Powerful engine and high technology systems provide you with enhanced performance and highest productivity.

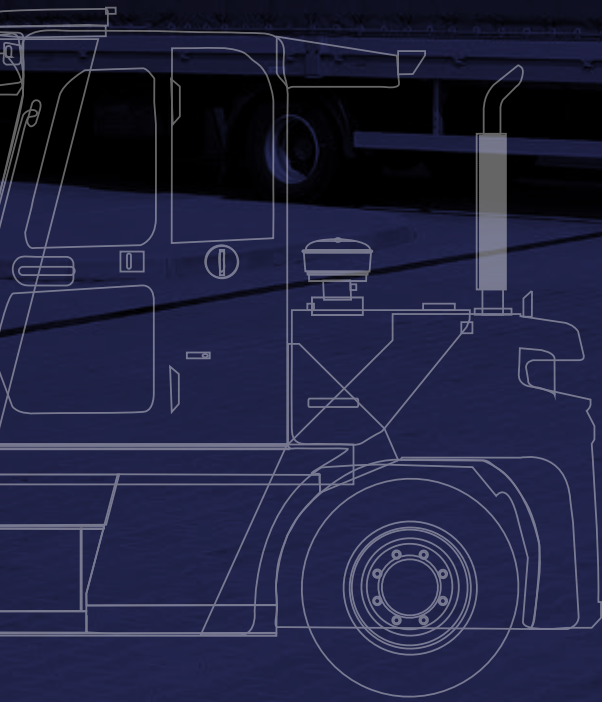

HIGH PERFORMANCE

POWERFUL ENGINE

Some of the photos may include optional equipment.

Powerful and economical Cummins QSF3.8 engine!

The adoption of a 4-cylinder Turbo Charger Cummins QSF3.8 engine ensures low vibration and improves low-temperature startability and white smoke generation in winter. Also, its fuel consumption has been decreased while power output has been increased due to the adoption of a direct injection system.

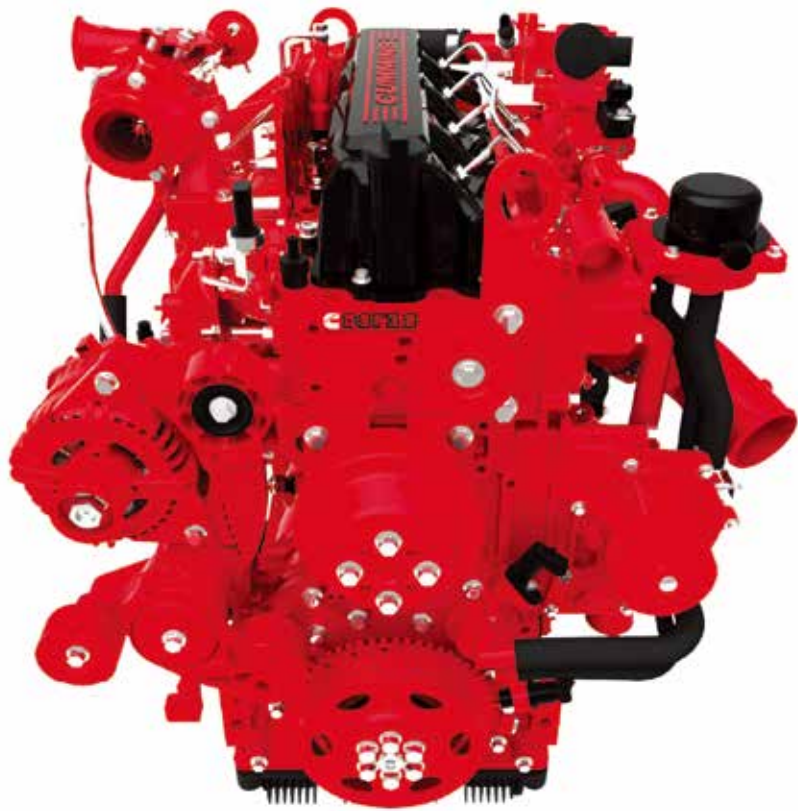

102PS/2,200rpm
2.3kgf · m/1,600rpm

Excellent gradeability and travel speed

The powerful engine provides greater acceleration, better gradability and faster travel speed on any tough terrains or slopes.

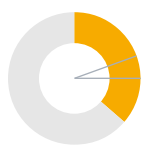

36.3% (19.9°)

Max. Gradeability (Loaded)



35km/h

Max. Travel Speed (Unloaded)



ZF Full-automatic transmission

Due to optimized engine and performance of the transmission, acceleration performance in low-speed sections has improved and noise heat generation has reduced. Also, it is possible to check the transmission status / failure etc. on the display window of the cluster.



Highly durable drive axle

The strengthened drive axle separable from transmission ensures low vibration and easy maintenance. The wet disc type brake is applied for easy operation, smooth response and maintenance free.



Fully hydraulic power steering

The hydraulic steering system guarantees smooth and flexible steering, preventing over-run and kick-back.



Mast Tilting Angle

The mast tilting angle of 15 degrees forward and 10 degrees backward, the operator can perform loading and unloading safely and rapidly.

Prompt and safe loading/unloading

The 68.6cc large-capacity tandem-type hydraulic pump, powerful engine torque of 42.3kgf.m, and weight distribution on the front and rear wheel axle optimized for rated load work guarantee prompt, safe and efficient loading/unloading.



Easy & Comfort

Best Convenience Optimized Ergonomics

The ergonomically designed cabin provides full support and comfort to the operator.



Some of the photos may include optional equipment.

Spacious operating space

The ergonomically designed operating space was made for more space, a wider field of view and operator comfort. The smooth lever and pedal operation, adjustable tilting handle, suspension seat and deluxe cabin provide comfortable and efficient operation.



Some of the photos may include optional equipment.



Grammer Seat (OPT)

Easily adjustable suspension seat, based on a human engineering design, reduces operator fatigue and provides greater comfort.

- Operator's weight range (45~170kg)
- ELR(Emergency Locking Retractor) type seat belt as a standard
- Heat wire and head rest (OPT)



New concept of centralized cluster

- Odometer
- Engine RPM
- Mast tilting status display
- Fuel gauge
- High beam indicator lamp
- Transmission oil temperature gauge
- Fuel heater operation lamp
- Air cleaner filter warning light
- Hour meter
- Diesel exhaust fluid shortage warning light
- T/M information display
- Parking brake operation display lamp
- Battery charging warning light
- Consumable replacement display lamp
- Engine warm-up display lamp
- Weight indicator (OPT)
- Real-time equipment tilt display
- Engine coolant temperature gauge
- Engine check warning light
- Seat belt warning lamp
- OPSS lamp
- Inching display lamp



High-Output Air Conditioner & Heater

Full Automatic Temperature Control automatically adjusts cabin temperature to the set temperature and provides more comfortable working environment for the operator.



Centralized Instrument Switch Panel

Various switches can be concentrated on the right side of the driver's seat to quickly optimize the vehicle condition to suit the working environment.



Quick Response of Operating Control Levers

Only minimal operator's effort is required for precise, safe and productive control.



Accelerator and inching pedals

Based on human engineering the accelerator, brake and inching pedals are optimally positioned for the operator's convenience.



Adjustable Steering Wheel

Steering wheel can be adjusted forward, backward, up and down for the most comfortable operator position.



Secure & Safety

Advanced Safety

The safely designed driver's space makes your operating more comfortable.

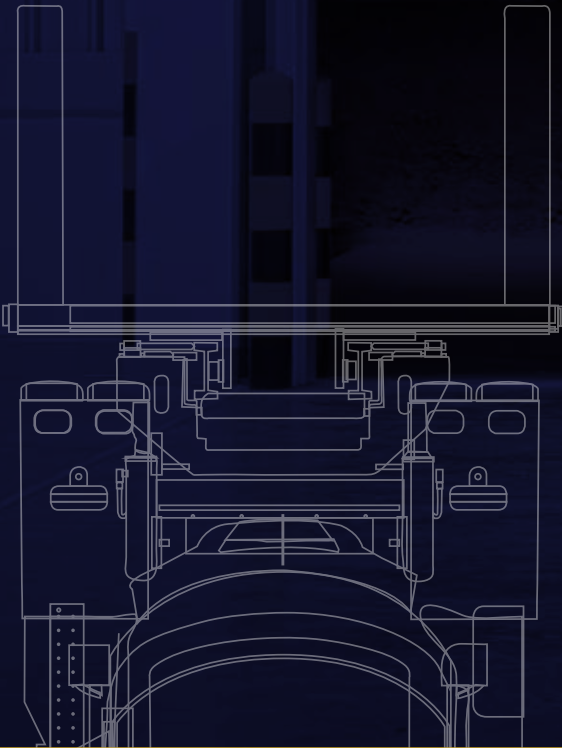

EXCELLENT VISIBILITY

Some of the photos may include optional equipment.

Wide visibility for Safe Operation

The optimized lift cylinder array design provides a clear, wide field of vision for the operator. The adoption of a panorama mirror and rear camera(OPT) improve the rear side view, further enhancing safety.



Some of the photos may include optional equipment.



Rear view camera (OPT)

The rear view camera and monitor connected with the reverse gear guarantee a safe working environment.



Large Footboard & Hand Grip

Wide openstep offers convenience and safety when entering and exiting vehicle.

Speed limit setting

As the vehicle's speed limit can be set in consideration of the operator's environment, accidents resulting from violations of the speed limit can be prevented.

Password setting function

The equipment can be managed safely and protected from theft by setting the password. (Up to 10 passwords can be set.)

Load weight indicator (OPT)

When lifting a load, a change in hydraulic pressure of the lift line is converted to a measurement of weight displayed in real time, and a warning is given at the time of overload.

Rear tire cover (STD) / Under cover (OPT)

The rear tire cover protect the the engine room by preventing foreign materials forme entering the tire. The Under cover protect the engine and components from dusts caused by ground.



Machine inclination warning system

The grade (left) and slope (right) sensors are built into the MCU and provide the grade and slope status information of the vehicle connected with the road surface condition in real time. Also, an alarm is emitted when the KS regulation is exceeded.

Safety features

The adoption of a high-sensitivity sensor and advanced safety system eliminates the risk of safety accidents.



Auto parking brake

If the operator leaves the seat while the gear lever is in neutral, the parking brake is automatically engaged to secure safety, and released upon the operator's return to the seat.

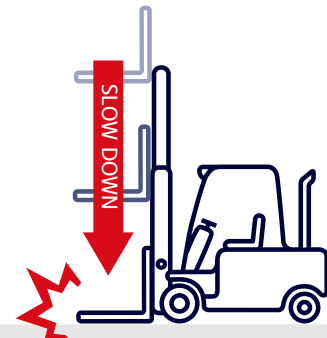

Fork Safety Features

The down-safety valve prevents forks from dropping down in case of sudden damage of hydraulic line.

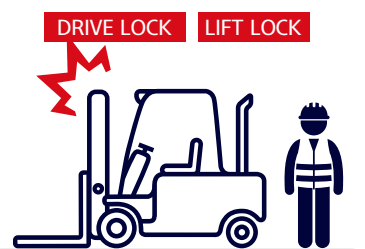

Operator Presence Sensing System

All mast and drive movements stop functioning when the operator is not in the seat.



High brightness headlamp / LED taillight

Adoption of a high brightness headlamp and a semi-permanent LED taillight improves work efficiency and safety.



Vibration absorbing bellows

The durability of the muffler and the exhaust pipe is improved by installing the vibration absorbing bellows in a part of the exhaust pipe connecting the engine exhaust manifold and the muffler.



Maintenance & Convenience

Fast and Easy Maintenance & Convenience Features

An ideal arrangement of components ensures easy access and convenience for maintenance.

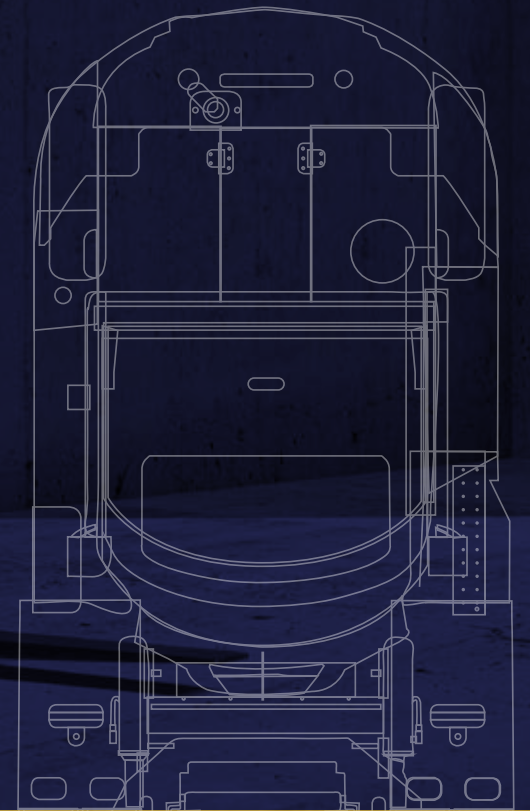

Some of the photos may include optional equipment.

Fully opening engine hood

An ideal arrangement of components ensures easy access and convenience for maintenance. Also, the adoption of a large-capacity double air cleaner filter ensures longer filter replacement cycle.



Some of the photos may include optional equipment.

Various convenience devices

Various functions provide safety and convenience for operator.



Engine fault diagnosis

Details of engine fault diagnosed by the engine control unit (ECU) can be checked on the cluster.



Maintenance management

Replacement cycle of consumable items can be checked on the monitor, thus preventing performance deterioration of major functional parts due to failure to notice deterioration.



Fuse box and relay box

The cabin is fitted with a newly developed fuel box and a relay box with waterproof and dustproof cover for ease of maintenance.



Easy battery check

Battery is installed under the left-side step of the forklift to ensure convenient and easy checking.



Cabin tilting switch

The cabin can be tilted up to 48 degrees with a single switch, making it easy to service the functions located under the driver's seat.



Fuel inlet lockable with key (OPT)

A locking device is installed at the fuel inlet to prevent equipment malfunction due to fuel stolen and foreign materials.



Easy-to-access washer tank

Level of washer fluid can be checked simply by opening the wing cover.



Easy-to-access inlet of diesel exhaust fluid

Diesel exhaust fluid inlet can be easily accessed for convenient injection.



Improved serviceability

Adoption of one-touch latch makes it easier to service the engine, components and electric parts.

Fleet Management System(Hi FLEET)(OPT)

Hi FLEET, Hyundai material handling's fleet management system, is the optimal operation solution for a fleet of forklifts. It connects driver and vehicle in real time.



You can see the video by scanning the QR code.

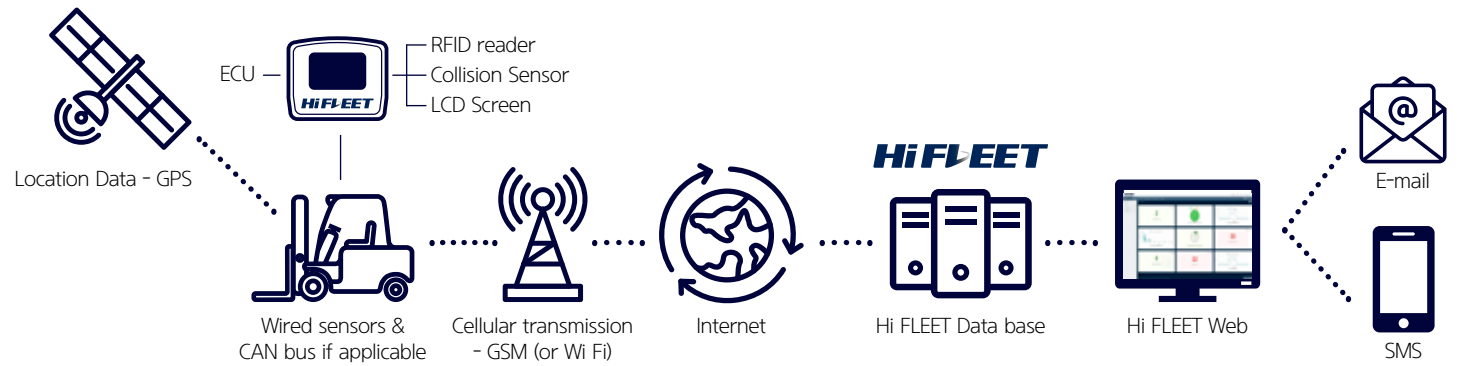

DRIVER MANAGEMENT

It is possible to certify drivers and manage their work through RFID, PIN password.

VEHICLE MANAGEMENT

You can check the operating time, battery status, and location information in real time.



SAFETY MANAGEMENT

You can check the driver's conditions and vehicle status before starting work and manage the speed and collision.

MAINTENANCE

You can keep your vehicles in optimal condition by notifying the vehicle's maintenance interval and fault codes.

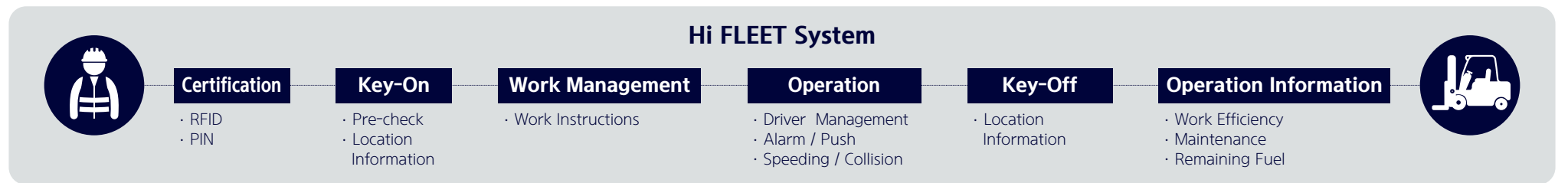

New 9 Series Mast Specification

80D-9

80D-9

Mast Type	Maximum Fork Lift Height	Overall Height (Fork Lowered)	Maximum height	Free lift height (with backrest)	Tilt Angle		Load Capacity (600mm LC)	Truck Weight	
					Fwd	Bwd			
	mm	mm	mm	mm	deg	deg	kg	kg	
2-Stage Limited free lift	V270	2,740	2,525	4,075	150	15	10	8,000	11,651
	※V300	3,040	2,675	4,375	150	15	10	8,000	11,699
	V330	3,340	2,825	4,675	150	15	10	8,000	11,749
	V350	3,540	2,925	4,875	150	15	10	8,000	11,781
	V370	3,740	3,025	5,075	150	15	10	8,000	11,814
	V400	4,040	3,175	5,375	150	15	10	8,000	11,862
	V450	4,540	3,475	5,875	150	15	10	8,000	12,074
	V500	5,040	3,725	6,375	150	15	10	8,000	12,156
	V550	5,540	3,975	6,875	150	15	10	8,000	12,305
	V600	6,040	4,225	7,375	150	15	10	7,900	12,320
	V700	7,040	4,725	8,375	150	15	10	7,500	12,520
V750	7,540	4,975	8,875	150	15	6	7,300	12,604	
3-Stage full freelif	TF/TS450	4,570	2,750	5,905	1,415	15	6	8,000	12,363
	TF/TS500	5,070	2,950	6,405	1,615	15	10	8,000	12,466
	TF/TS550	5,570	3,150	6,905	1,815	15	10	8,000	12,569
	TF/TS600	6,070	3,350	7,405	2,015	15	10	7,800	12,671
	TS765	7,650	3,970	8,985	2,635	15	10	7,050	12,928

※ : Standard

80D-9 hook-type fork and when carriage is installed

Mast Type	Maximum Fork Lift Height	Overall Height (Fork Lowered)	Maximum height		Free lift height		Tilt Angle		Load Capacity (600mm LC)	Truck Weight	
			w/o backrest	with backrest	w/o backrest	with backrest	Fwd	Bwd			
	mm	mm	mm	mm	mm	mm	deg	deg	kg	kg	
2-Stage Limited free lift	V270	2,740	2,525	4,048	4,050	150	150	15	10	8,000	11,666
	※V300	3,040	2,675	4,348	4,350	150	150	15	10	8,000	11,714
	V330	3,340	2,825	4,648	4,650	150	150	15	10	8,000	11,765
	V350	3,540	2,925	4,848	4,850	150	150	15	10	8,000	11,796
	V370	3,740	3,025	5,048	5,050	150	150	15	10	8,000	11,829
	V400	4,040	3,175	5,348	5,350	150	150	15	10	8,000	11,877
	V450	4,540	3,475	5,848	5,850	150	150	15	10	8,000	12,089
	V500	5,040	3,725	6,348	6,350	150	150	15	10	8,000	12,171
	V550	5,540	3,975	6,848	6,850	150	150	15	10	8,000	12,320
	V600	6,040	4,225	7,348	7,350	150	150	15	10	7,900	12,335
	V700	7,040	4,725	8,348	8,350	150	150	15	10	7,500	12,535
V750	7,540	4,975	8,848	8,850	150	150	15	6	7,300	12,619	
3-Stage full freelif	TF/TS450	4,570	2,750	5,902	5,880	1,418	1,440	15	6	8,000	12,378
	TF/TS500	5,070	2,950	6,402	6,380	1,618	1,640	15	10	8,000	12,481
	TF/TS550	5,570	3,150	6,902	6,880	1,818	1,840	15	10	8,000	12,584
	TF/TS600	6,070	3,350	7,402	7,380	2,018	2,040	15	10	7,800	12,686
	TS765	7,650	3,970	8,985	8,963	2,638	2,660	15	10	7,050	12,943

※ : Standard

New 9 Series

80D-9

Load Capacity

80D-9

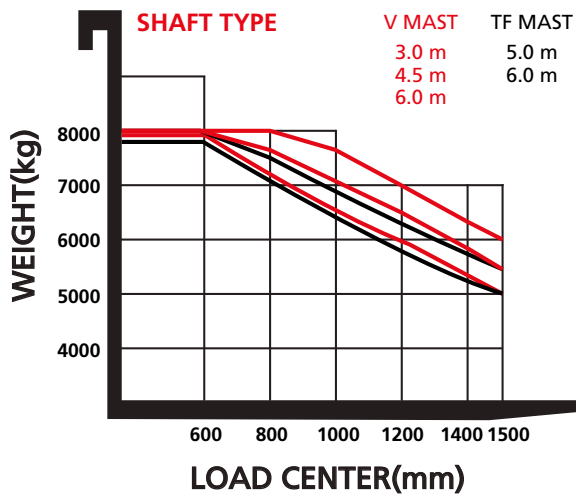

Optional Items

- Fork (mm)
80D-9 : 1200(STD), 1350, 1500, 1800, 2000, 2150, 2200, 2400
- TIRE : Solid / Non-marking
- M.C.V : 2/3/4/5 spool (4 spool: standard)
- Load weight indicator
- Rear view camera
- One-piece side shift carriage, one-piece side shift + fork positioner carriage
- 80D-9 hook-type carriage, one-piece shaft-type carriage
- Seat : Grammer heated wire + headrest seat
- OHG (A/C, Heater)
- Master switch
- Undercover
- LED warning light (Amber)
- TOP WIPER

Attachments

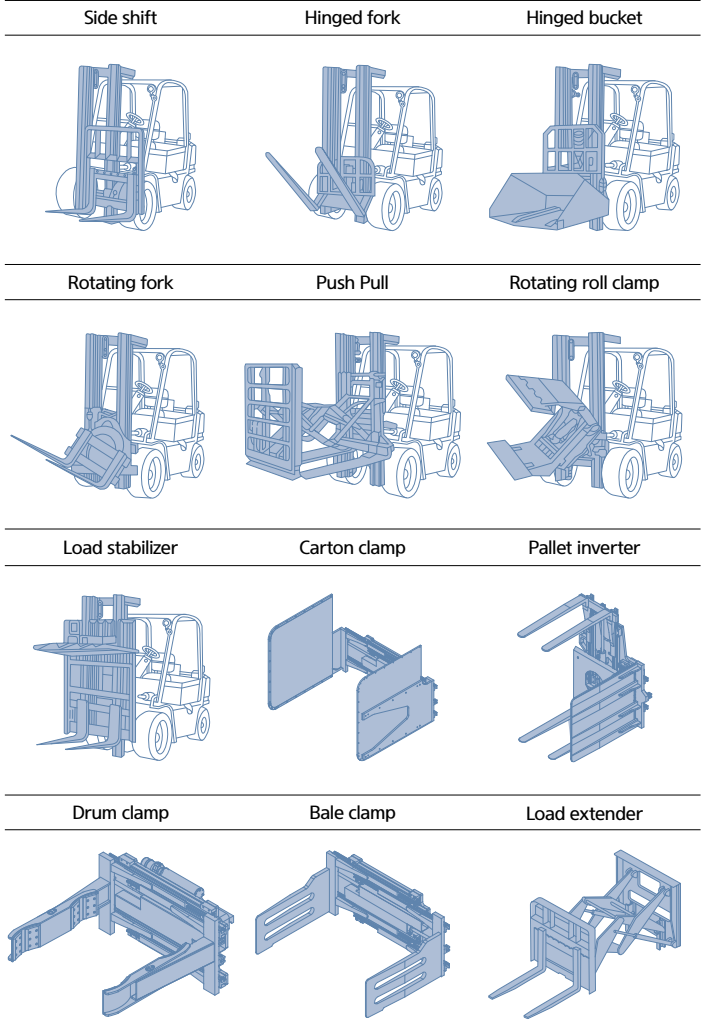

* All specifications and photos in this catalog are subject to change for quality improvement.

New 9 Series

Specification

Distinguishing mark			
1.1	Manufacturer		Hyundai
1.2	Manufacturer's type designation		80D-9
1.3	Drive		Diesel
1.4	Type of operation		Seat type
1.5	Load capacity	kg	8,000
1.6	Load center distance	c mm	600
1.8	Load center distance	x mm	690
1.9	Wheelbase	y mm	2,500
Weight			
2.1	Service weight	kg	11,700
2.2	Axle loading, loaded front/rear	kg	17,258 / 2,442
2.3	Axle loading, unloaded front/rear	kg	5,130 / 6,570
Tires, chassis			
3.1	Tires : Pneumatic(P),Solid rubber(V),Non marking (N)		P
3.2	Tire size, front (Ø x width)		9.00-20-14PR
3.3	Tire size, rear (Ø x width)		9.00-20-14PR
3.5	Wheels, number front / rear (x = drive wheels)		4 x / 2
3.6	Tread, front	mm	1,632
3.7	Tread, rear	mm	1,700
Dimensions			
4.1	Tilt angle(forward/backward)	deg	15 / 10
4.2	Height, mast lowered	h1 (mm)	2,675
4.3	Free lift	h2 (mm)	145
4.4	Lift height	h3 (mm)	3,040
4.5	Height, mast extended	h4 (mm)	4,375
4.7	Height of head guard (cabin)	h5 (mm)	2,615(2,640)
4.8	Seat height	h7 (mm)	1,650
4.12	Coupling height	h10 (mm)	508
4.19	Overall length	l1 (mm)	5,171
4.20	Length to face of forks	l2 (mm)	3,971
4.21	Overall width	b1 (mm)	2,268
4.22	Fork dimensions (l x w x t)		1,200 x 180 x 70
4.23	Fork carriage iso 2328		Class IV
4.24	Fork-carriage width	b3 (mm)	2,277
4.31	Ground clearance, below mast,	m1 (mm)	250
4.32	Ground clearance, center of vehicle	m2 (mm)	302
4.33	Cross-passage width (pallet 1000x1200)	Ast (mm)	5,590
4.34	Aisle width of pallets 800 x 1200 crossways (w x l)	A st (mm)	5,790
4.35	Turning radius	Wa (mm)	3,700
4.36	Smallest pivot point distance	b10 (mm)	1,354

Performance data			
5.1	Travel speed, unloaded	km/h	35
5.2	Fork lift speed, loaded / unloaded	mm/s	390 / 450
5.3	Fork descending speed, loaded / unloaded	mm/s	500 / 500
5.5	Max. drawbar pull, loaded	kgf	7,237
5.7	Gradeability, loaded	%	36.3
5.10	Service brake		Hydraulic
Engine			
7.1	Manufacturer/model name		CUMMINS / QSF3.8
7.2	Rated power	ps / rpm	102 / 2,200
7.3	Max. torque	kgf.m / rpm	42.3 / 1,600
7.4	Number of cylinders / displacement	EA / cc	4 / 3,726
7.5	Fuel tank capacity	ℓ	171.5
Addition data			
8.2	Max. hydraulic pressure(system/attachment)	bar	210 / 150
8.3	Attach oil flow rate	ℓ	115

Dimension

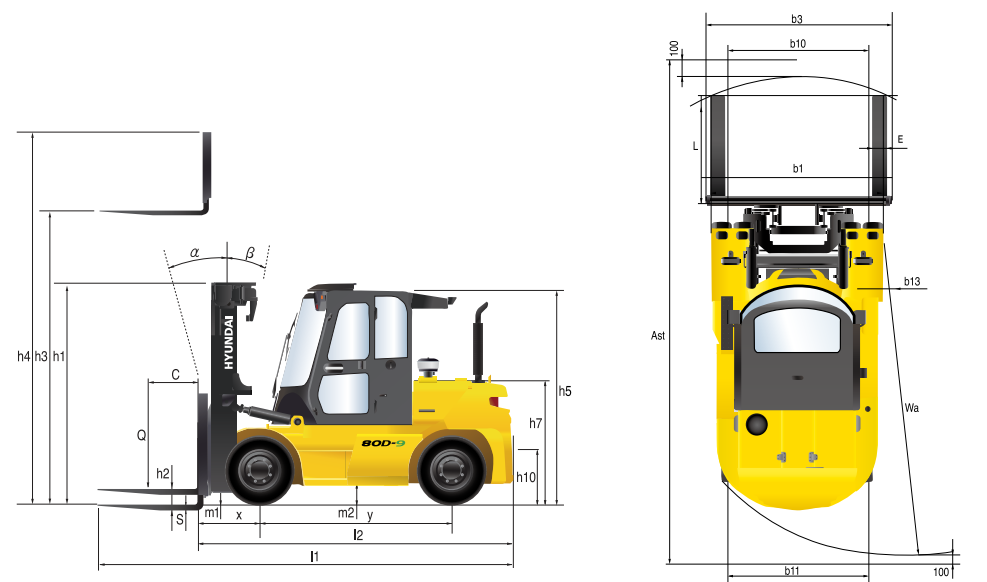

* All specifications in this catalog are subject to change according to the optional items.

