



FE16H/18H/20H

三支点蓄电池平衡重式叉车

THREE-WHEEL ELECTRIC FORKLIFT

ZOOMLION

中联重科安徽工业车辆有限公司
ZOOMLION ANHUI INDUSTRIAL VEHICLE CO.,LTD
 地址：中国 安徽省芜湖市弋江区高新技术产业开发区南纬一路2号
 Add: No.2 Nanwei Road Area of high-tech Development Zone,Wuhu, Anhui Province,P.R.China
 电话(TEL): 0553-3020213 热线 (HOTLINE): 400-8875860
 邮编 (POST): 241000 网址 (Website): www.zoomlionfl.com



ZOOMLION

三支点蓄电池平衡重式叉车

THREE-WHEEL ELECTRIC FORKLIFT

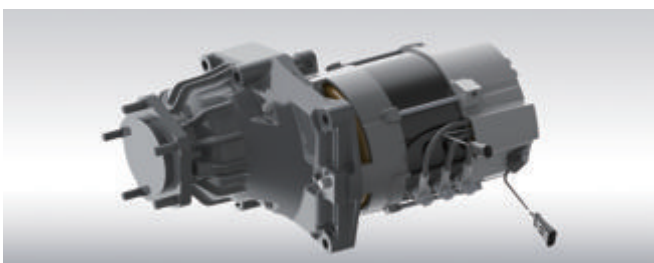

全交流驱动系统，进口湿式制动器。
 Full AC drive system, imported wet brake.

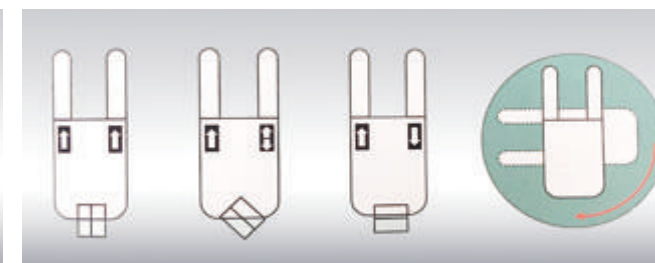

前轮双电机独立驱动，电脑控制方向、速度，转弯半径小、灵活方便。
 The front wheel is driven by two independent motor, with the increase of the steering angle, the output speed of the two motors is different realizing forklift in-situ rotation.



三级全自由门架采用前两大缸设计，大大增加驾驶视野。
 Mast triple full free equipped with double front cylinder, increasing greatly the driver operating field of vision.



完全按人机工程设计的集成式操作手柄，集起升、下降、前倾、后倾、侧移以及急停开关、喇叭、灯光控制等各种控制按钮于一体，单手即可完成所有操作，极大提高了操作效率。
 Optional fingertip control system set to rise and fall, forward, backward, lateral and emergency stop switch, a horn, lighting control and other control buttons in one.



侧置式操纵手柄设计，操纵手柄支点位于多路阀芯的后部，更靠近驾驶员，符合驾驶员操作的人机工程。
 Advanced suspension seat with suspension damping function, which can ease the driver fatigue, and improve work efficiency.



门架智能缓冲系统，当货叉落地时，下降速度会自动降低，以防止货物受到撞击造成的损坏。
 Mast intelligent buffer system, when the fork falls to the ground, the descent speed will be automatically reduced to prevent the damage to the goods from impact of vehicle.



侧取式电瓶结构设计，更换蓄电池更方便。
 The battery cover adopts hydraulic tappet support, it can be fully opened, easy to maintain the battery.



打开平衡罩，即可进行电气维修保养。
 Open the balance heavy cover, you can control the electrical maintenance.



LED显示仪表，操作方便，整车数据、信息更丰富、直观。
 With multi-function LCD display users can easily monitor the performance and working status of the vehicle through the information displayed on the display.

ZOOMLION

整机参数 Machine Parameters

特性	Characteristics		FE16H	FE18H	FE20H
驱动	Drive type	/	蓄电池	蓄电池	蓄电池
驾驶方式	Driving mode	/	座驾式	座驾式	座驾式
承载能力	Capacity	Q(kg)	1600	1800	2000
载荷中心距	Load center distance	c(mm)	500	500	500
前悬距	Front overhang	x(mm)	403	403	403
轴距	Wheelbase	y(mm)	1360	1360	1470
重量	Weight				
自重 (含蓄电池)	Curb weight (with battery)	kg	3170	3250	3220
满载轴负荷 前/后	Full load axial load	kg	4260/490	4590/460	5020/430
空载轴负荷 前/后	No load axial load	kg	1600/1590	1590/1680	1680/1680
轮胎	Tyre				
轮胎类型	Tyre type	/	实心胎	实心胎	实心胎
轮胎型号, 前	Tire type, front	/	18X7-8	18X7-8	18X7-8
轮胎型号, 后	Tire type, rear	/	15X4.5-8	15X4.5-8	15X4.5-8
车轮数量 前/后 (x=驱动)	Number of wheels front / rear (x= drive)	/	2x/2	2x/2	2x/2
轮距, 前	Tread width, front	b10(mm)	920	920	960
轮距, 后	Tread width, rear	b11(mm)	180	180	180
尺寸	Size				
货叉滑架 前倾/后倾	The fork carriage forward / backward	°	6/6.5	6/6.5	6/6.5
门架落地高度	Mast lowered height	h1(mm)	2020	2020	2020
自由起升高度	Free lift height	h2(mm)	1106	1106	1106
起升高度	Lifting height	h3(mm)	3000	3000	3000
门架起升全高	Mast extended height	h4(mm)	4024	4024	4024
驾驶室高度	Cab height	h6(mm)	2050	2050	2050
座椅高度	Seat height	h7(mm)	890	890	890
牵引高度	Traction height	h10(mm)	455	455	455
总体长度	Overall length	L1(mm)	2885	2885	2995
至叉面长度	Length to fork face	L2(mm)	1960	1960	2074
总体宽度	Overall width	b1 / b2(mm)	1090	1090	1170
货叉尺寸	Fork size	s/e/l(mm)	40/100/920	40/100/920	40/100/920
门架离地间隙, 满载	Mast ground clearance	m1(mm)	90	90	90
轴距中心离地间隙	Wheelbase center clearance	m2(mm)	90	90	90
托盘为 1200宽 × 1000长的通道宽度	Width of transverse channel with 1000 x 1200 pallet	Ast1(mm)	3299	3299	3406
托盘为 800宽 × 1200长的通道宽度	Width of transverse channel with 1200 x 800 pallet	Ast2(mm)	3426	1575	1680
转弯半径	Turning radius	Wa(mm)	1575	3426	3533
性能	Performance				
行驶速度 满载/空载	Travel speed full-loaded / no-loaded speed	km/h	13/14	13/14	13/14
起升速度 满载/空载	Lifting speed full-loaded/ no-load	mm/s	320/400	320/400	300/390
下降速度 满载/空载	Lowering speed full-loaded / no-loaded	mm/s	405/400	405/400	405/400
最大爬坡度 5min 满载/空载	Maximum gradeability 5min full-loaded / no-loaded	%	12/15	11/15	10.5/15
制动方式	Braking mode	/	液压/机械	液压/机械	液压/机械
动力	Power				
驱动电机额定功率, S2 60min	Drive motor rated power, S2 60min	kw	4.8x2	4.8x2	4.8x2
起升电机额定功率, S3 15%	Lifting motor rated power, S3 15%	kw	11	11	11
蓄电池 电压/容量 5小时放电率	Battery voltage / capacity 5 hours discharge rate	V/Ah	48/500	48/500	48/600
蓄电池自重	Battery weight	kg	900	900	1005
其他	Other				
驱动控制方式	Drive control mode	/	AC	AC	AC
驾驶员耳边噪音 EN 12053	Sound level at the driver's ear acc. to DIN 12053	dB(A)	75	75	75

M 宽视野基本型门架 (M Wide View Standard Mast)

起升高度 Lifting height	承载能力 Loading capacity			门架高度 Mast lowered height		自由起升高度 Free lifting height	门架倾角 Mast tilt Angle f/r
	mm/in	1.6T(kg/lb)	1.8T(kg/lb)	2.0T(kg/lb)	落地 Forks landing(mm/in)		
2000/79	1600/3527	1800/3968	2000/4409	1520/60	3024/119	8/3.35	6/6.5
2500/98	1600/3527	1800/3968	2000/4409	1770/70	3524/139	8/3.35	6/6.5
2700/106	1600/3527	1800/3968	2000/4409	1870/74	3724/147	8/3.35	6/6.5
3000/118	1600/3527	1800/3968	2000/4409	2020/80	4024/158	8/3.35	6/6.5
3300/130	1600/3527	1800/3968	2000/4409	2170/85	4324/170	8/3.35	6/6.5
3500/138	1600/3527	1800/3968	2000/4409	2270/89	4524/178	8/3.35	6/6.5
4000/157	1500/3307	1600/3527	1800/3968	2570/101	5024/198	8/3.35	3/5
4250/167	1400/3086	1500/3307	1700/3748	2695/106	5274/208	8/3.35	3/5
4500/177	1350/2976	1400/3086	1600/3527	2820/111	5524/217	8/3.35	3/5

S 三节全自由门架 (S 3s-stage full free mast)

起升高度 Lifting height	承载能力 Loading capacity			门架高度 Mast lowered height		自由起升高度 Free lifting height	门架倾角 Mast tilt Angle f/r
	mm/in	1.6T(kg/lb)	1.8T(kg/lb)	2.0T(kg/lb)	落地 Forks landing(mm/in)		
4000/157	1450/3197	1550/3417	1650/3638	1940/76	5024/198	891/35	3/5
4350/171	1350/2976	1450/3197	1600/3527	2055/81	5374/212	1056/42	3/5
4500/177	1300/2866	1350/2976	1500/3307	2105/83	5524/217	1106/44	3/5
4800/189	1200/2646	1250/2756	1400/3086	2205/87	5824/229	1206/47	3/5
5000/197	1150/2535	1200/2646	1350/2976	2270/89	6024/237	1271/50	3/5
5500/217	1050/2315	1100/2425	1250/2756	2490/98	6554/258	1491/59	3/5
6000/236	850/1874	900/1984	1150/2535	2655/105	7054/278	1656/65	3/5

载荷曲线图 (CAPACITY CHART)

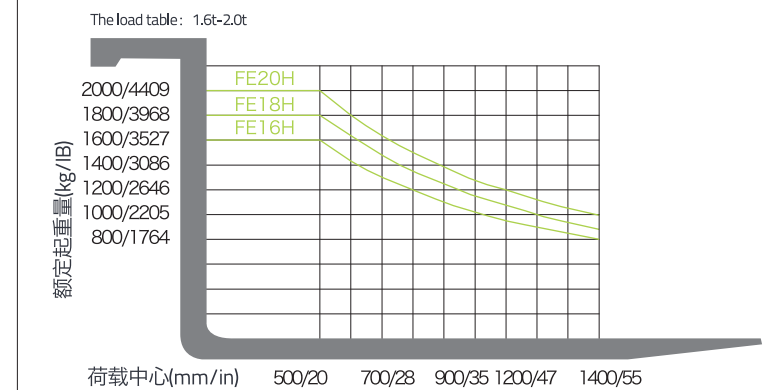

整机二维图 (Machine 2D graph)

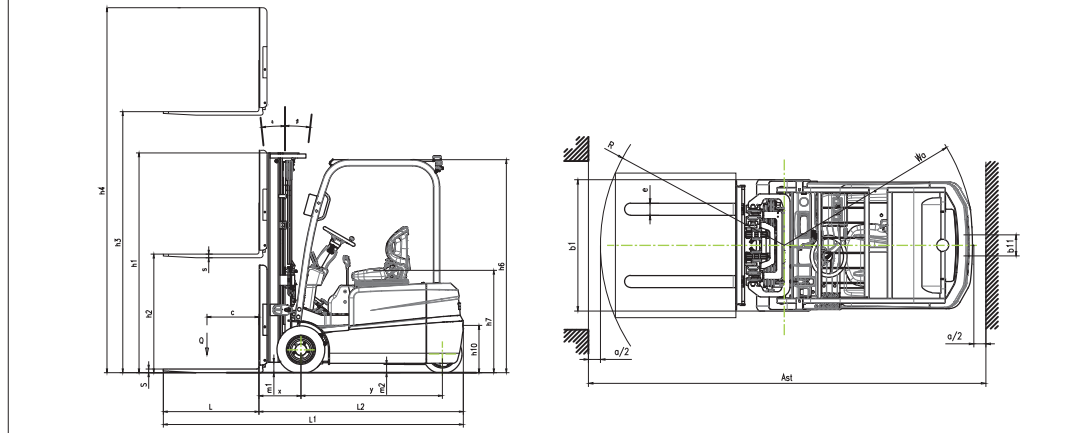

标准装备 (Standard Equipment)

• 宽视野门架	Wideview mast	• 计时表	Timer	• 油压报警	Oil pressure alarm
• 手柄	Handle	• 组合仪表	Combined instrument pannel	• 随车工具	Toolbox
• 悬浮座椅	Suspension seat	• 电喇叭	Electric Horn	• 水温表	Water temperature gauge
• 挡货架	Backrest	• 转向指示灯	Turning signal	• 液压回油滤芯	Hydraulic oil return filter
• 倒车灯	Reversing light	• 制动器	Service brake	• 液压吸油滤芯	Hydraulic oil intake filter
• 倒车蜂鸣器	Parking buzzer	• 拉索式驻车制动	Parking brake	• 液压油标尺	Hydraulic oil level gauge
• 倒车镜	Rearview mirror	• 起升倾斜操纵杆	Lifting & tilting handle		
• 灯光开关	Light switch	• 起升油路限速阀	Speed limit valve		
• 护顶架	Overhead guard	• 橡胶踏板垫	Rubber pad		
• 二片多路阀	2 piece multi valve	• 照明	Headlamp		
• 护灯架	Lamp bracket	• 倾斜可调方向盘	Adjustable steering wheel		
• 后尾灯	Rear lamp	• 倾斜油路自锁	Hydraulic tilt lock		
• 耐用花纹轮胎	Durable pneumatic tire	• 钥匙开关	Key switch		

选配件 (Options)

○ 前挡风玻璃	Windshield
○ 带安全开关悬浮座椅	Suspension seat with safety switch
○ 倾斜油缸防尘套	Tilt cylinder dust cover
○ 小风扇	Mini fan
○ 转弯可自动限速	Automatic Turning speed limit
○ 倾斜油缸防尘套	Tilt/Turn cylinder cover
○ 低阻力轮胎	Low rolling resistance tyre
○ 实心轮胎	Solid tyre
○ 灭火器	Fire extinguisher
○ 钢防护网	Steel Grid guard
○ 旋转警示灯	Rotary work alarming light
○ LED灯	LED lamp
○ 后大灯	Rear light
○ 用户指定颜色	Optional painting
○ 着色轮胎 (白/绿)	Color tire (white/green)

属具 (Attachment)

○ 串杆	Carpet boom
○ 吊钩	Hook
○ 起重臂	Lifting boom
○ 倾翻叉	Hinged fork
○ 纸卷夹	Paper roll clamp
○ 多用桶夹	Barrel clamp
○ 加长货叉	Extended fork
○ 加宽货叉架	Extended Lift Bracket
○ 载荷稳定器	Load stabilizer
○ 加长货叉套	Fork cover
○ 旋转平抱夹	Revolving Flat Clamps
○ 宽视野二节/三节全自由门架	Wide view duplex/triplex full free mast
○ 侧移器	Side shifter